

INSTALLATION GUIDE

M1645G

Item Checklist

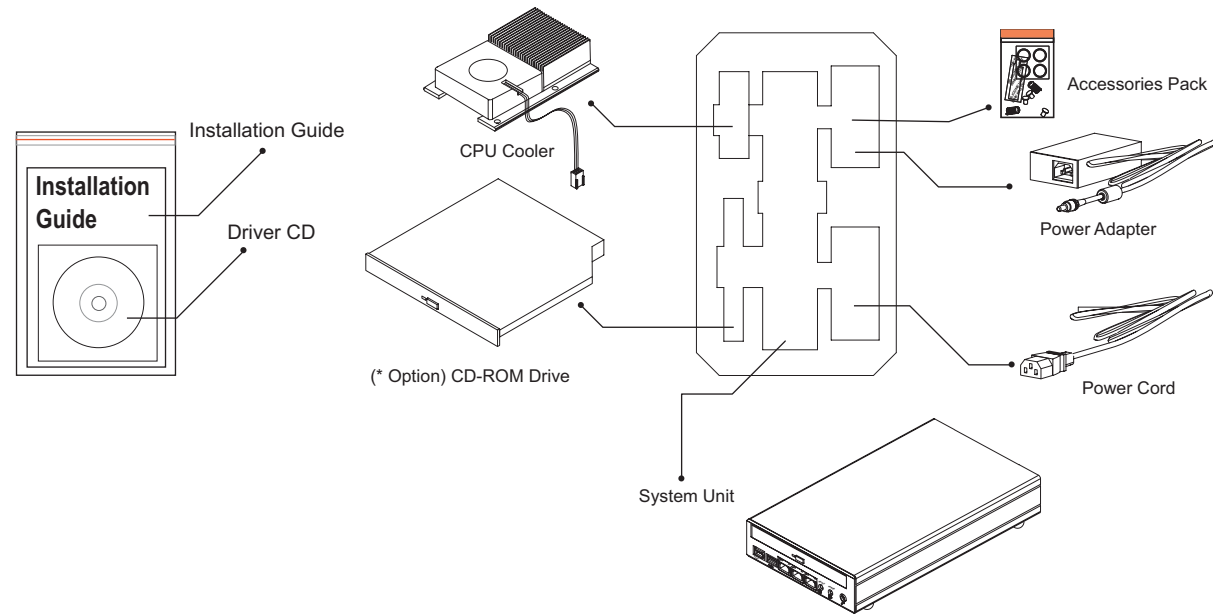

Barebone System Unpacking Guide

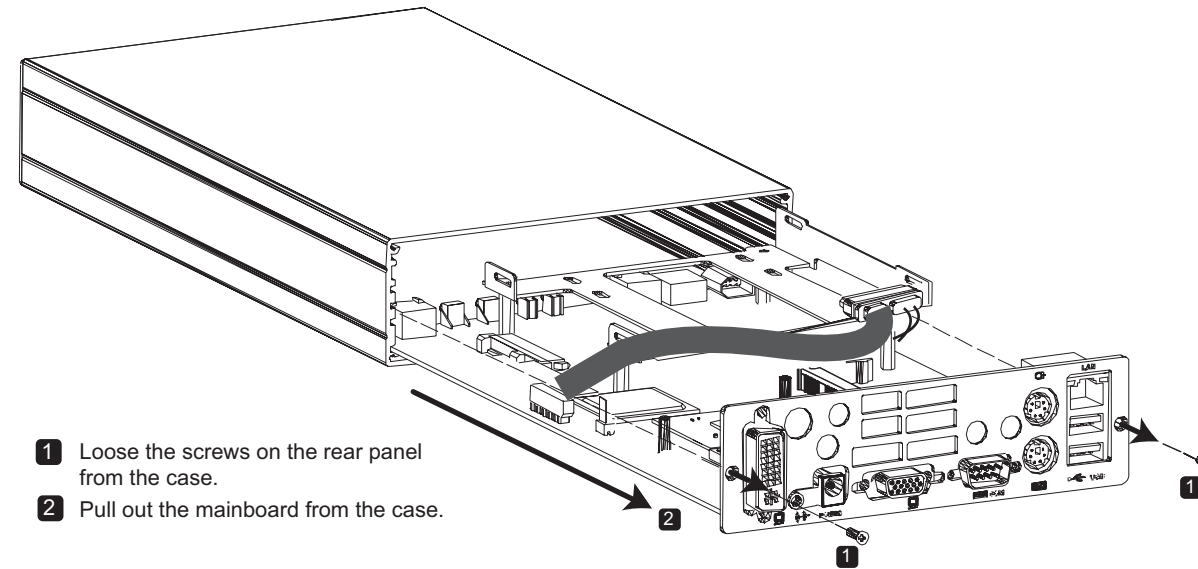

Install Memory

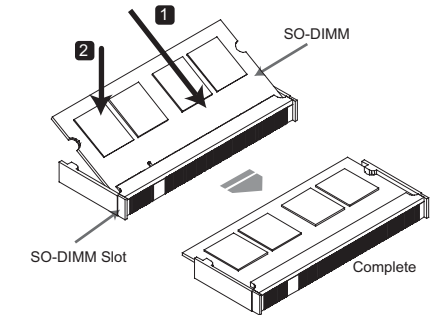

Mainboard and Optional Daughter Boards' Layout

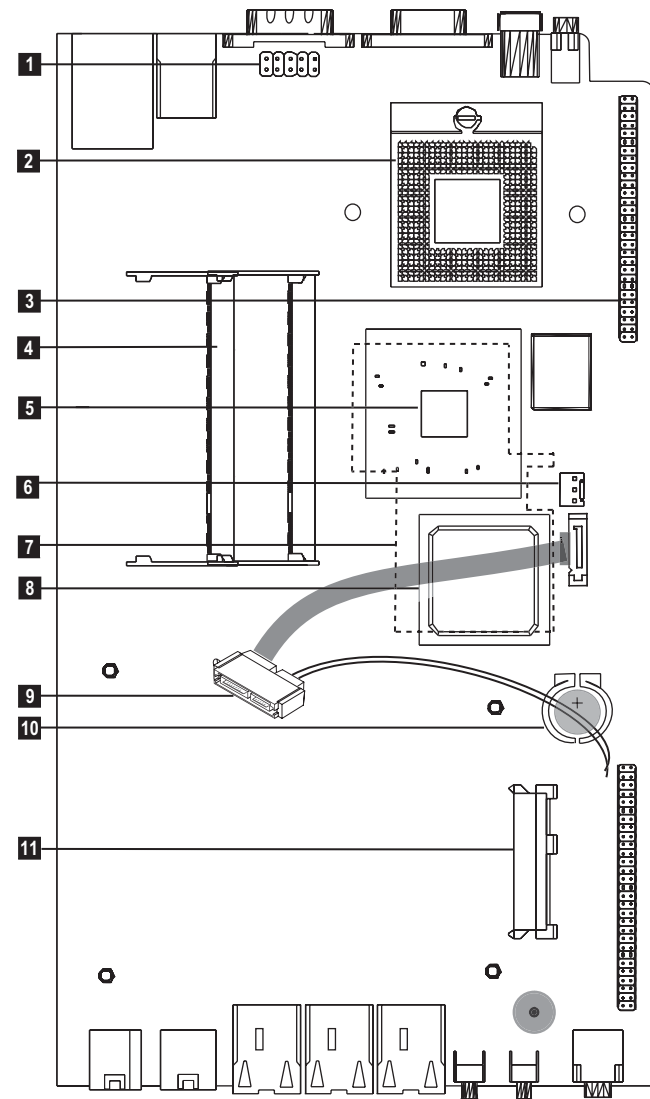

1	Optional COM 2 Connector
2	CPU Socket
3	DVI & LANs Adapter Slot
4	SO-DIMM Slots
5	Intel GM45 Chip
6	CPU Cooling Fan Connector
7	Chipset Heat Sink
8	Intel ICH9M Chip
9	SATA CD-ROM Drive Cable
10	CMOS Battery
11	SATA HDD Connector

A1	RJ45 LAN Port
A2	USB Ports
A3	PS/2 Mouse Port
A4	PS/2 Keyboard Port
A5	RS233/COM 1 Port
A6	VGA Port
A7	DC 12V Power In
A8	Line-Out Port
A9	DVI-D Port

B1	Mic-In Phone Jack
B2	Power Button
B3	Reset Button
B4	Three RJ45 LAN Ports
B5	USB Port
B6	Firewire(1394) Port

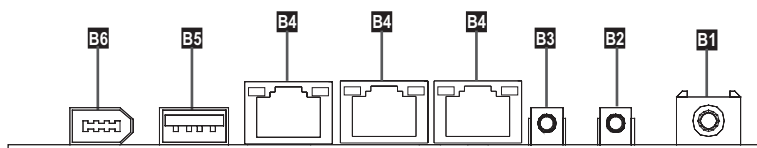
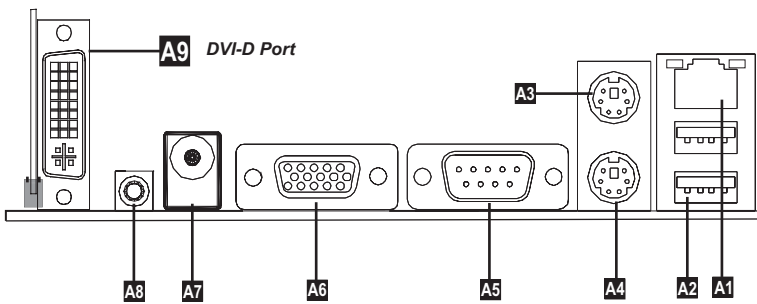

Install CPU & CPU Cooler

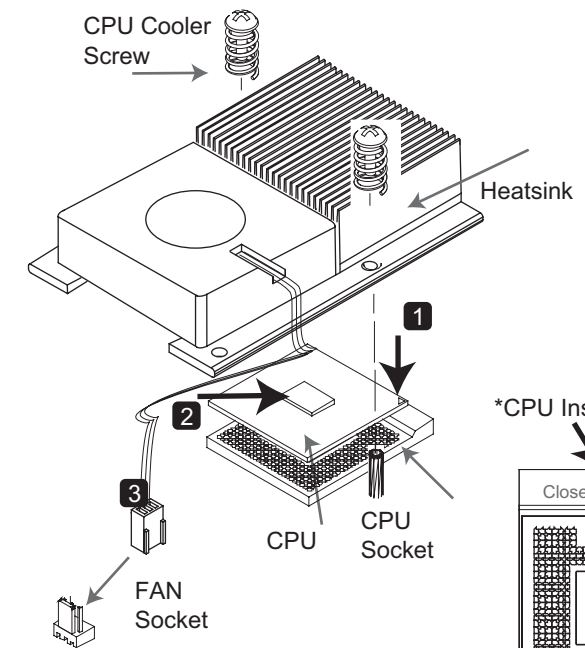

*CPU Install NOTICE

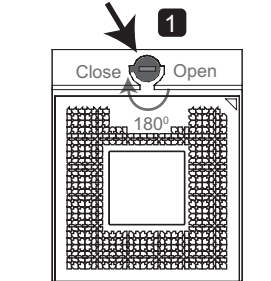

- 1 Install CPU into CPU socket. Match socket pin 1 and CPU cut edge. Screw down the black button to fasten the CPU.
- 2 Glue the heatsink compound on the CPU die surface. Install CPU cooler on top of CPU. Tighten CPU cooler with screws into pillaret.
- 3 Connect CPU FAN connector to mainboard CPU FAN socket.

Hardware Installation

Part List

- (A) COM/DVI Screws (* 6)
- (B) CD-ROM Drive Bracket
- (C) Front Panel
- (D) Rear Panel
- (E) Case
- (F) Mainboard
- (G) CPU Cooler
- (Q) DVI & 3 Giga LAN Daughter Board

Accessory Pack

- (H) EMI Sticker (*2)
- (I) Rubber Stand (*4)
- (J) 2.5" HDD Screws (* 5)
- (K) CD-ROM Screws (* 5)
- (L) Case Screws (* 2)
- (M) CPU Cooler Screws (* 2)
- (N) CPU Cooler Paste (* 1)

STEP 1

Install Slim HDD

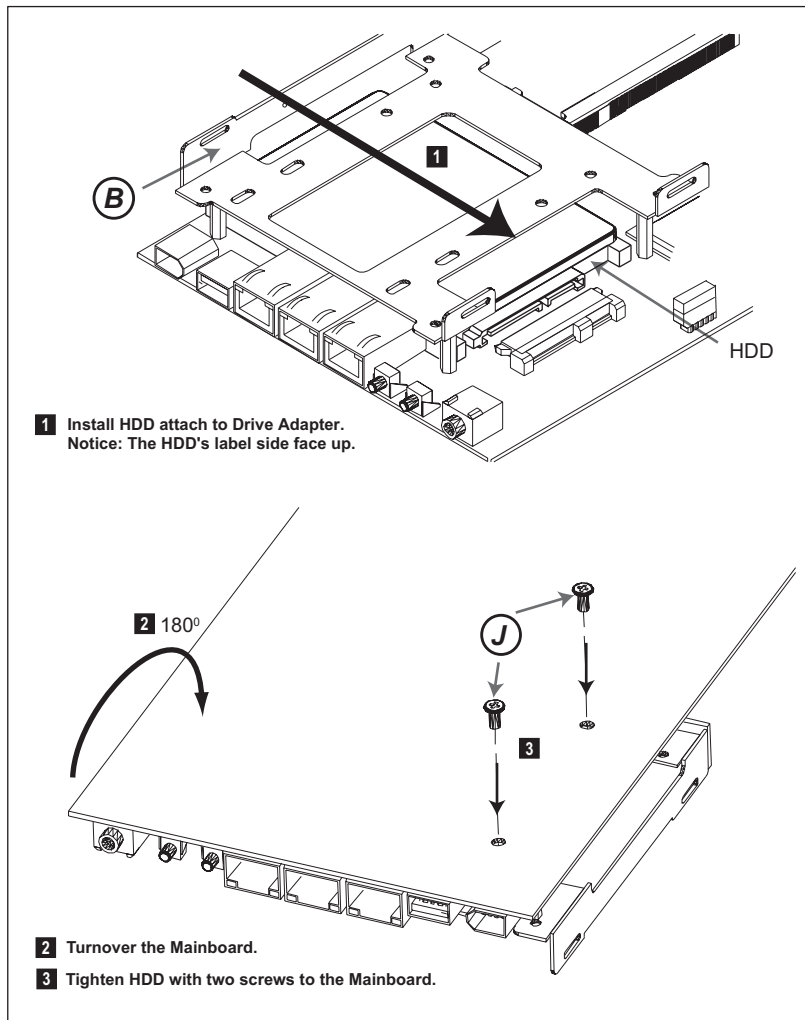

STEP 2

Install CD-ROM

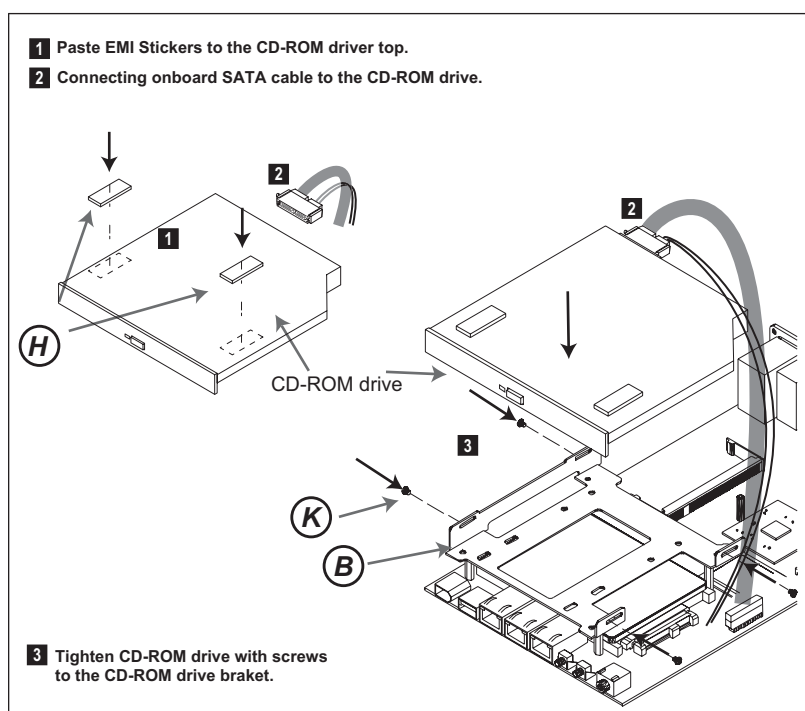

STEP 3

Install Case

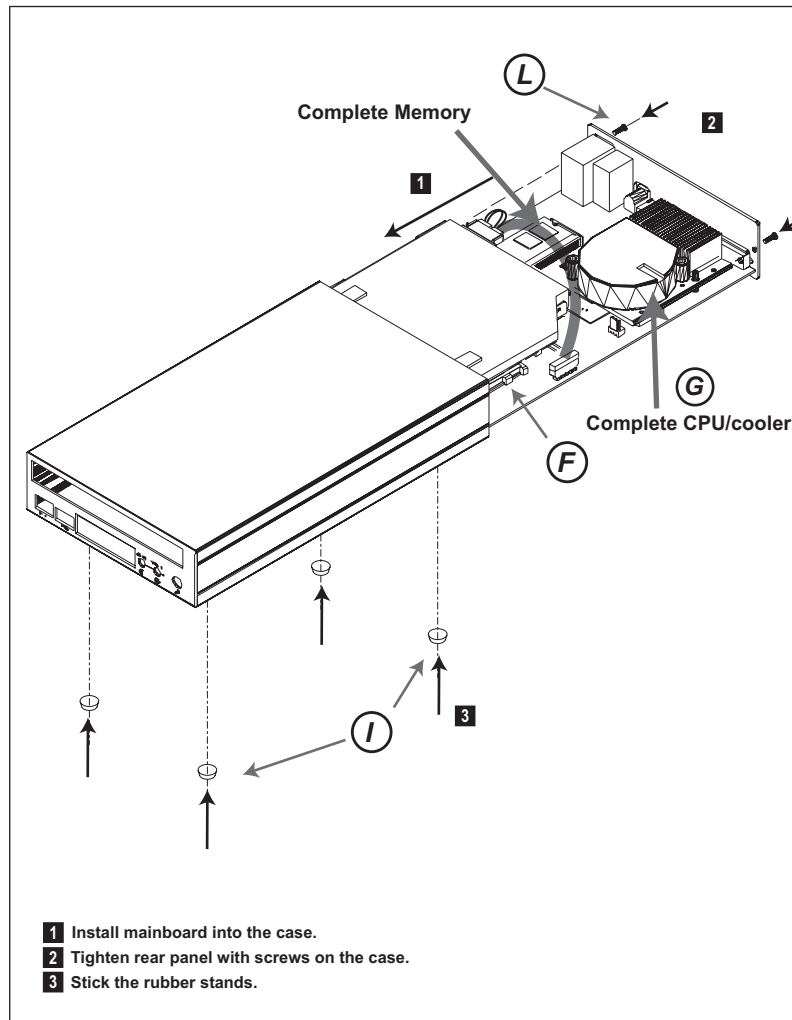

Complete System

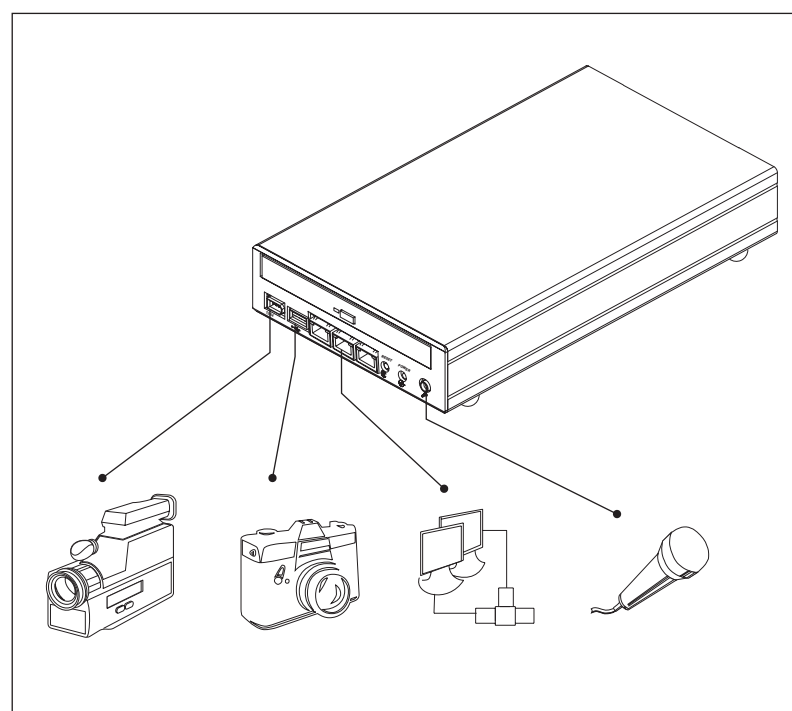

WARNING

This equipment has been tested and found to comply with the limits for a Class B digital device, pursuant to Part 15 of the FCC rules. These limits are designed to provide reasonable protection against harmful interference when the equipment is operated in a residential installation. This equipment generates, uses, and can radiate radio frequency energy and if not installed and used in accordance with the instruction manual may cause harmful interference to radio communications. However, there is no guarantee that interference will not occur in a particular installation. If this equipment does cause harmful interference to radio or television reception, which can be determined by turning the equipment off and on, the user is encouraged to try to correct the interference by one or more of the following measures:

- * Reorient or relocate the receiving antenna.
- * Increase the separation between the equipment and receiver.
- * Connect the equipment into an outlet on a circuit different from that to which the receiver is connected.
- * Consult the dealer or an experienced radio TV technician for help.

Notice: The changes or modifications not expressly approved by the party responsible for compliance could void the user's authority to operate the equivalent.

The system uses entire casing for partial heat dissipation, so the normal operating temperature is between 40°C ~ 55°C.